

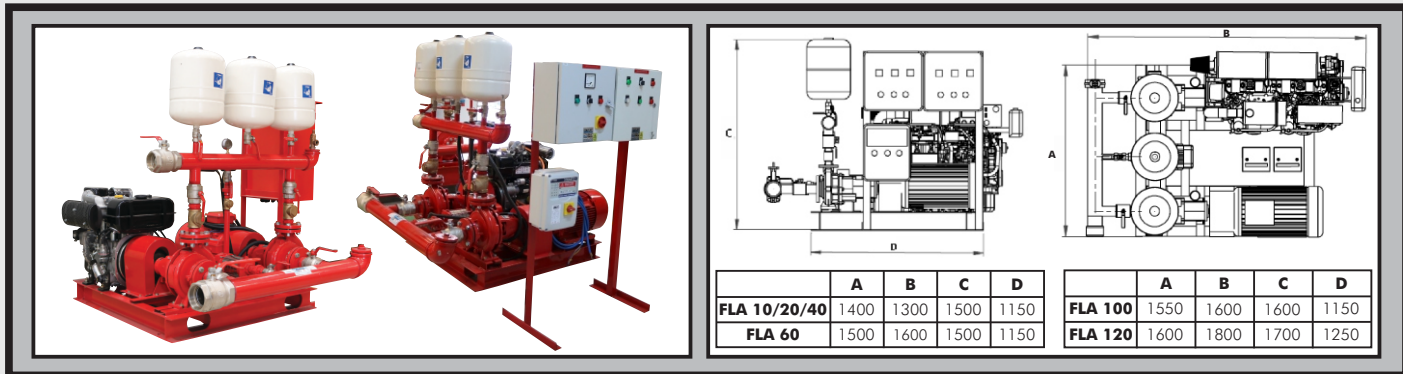

# FLA Fire Sets



	A	B	C	D
<b>FLA 10/20/40</b>	1400	1300	1500	1150
<b>FLA 60</b>	1500	1600	1500	1150

	A	B	C	D
<b>FLA 100</b>	1550	1600	1600	1150
<b>FLA 120</b>	1600	1800	1700	1250

DAYLIFF FLA packaged Fire Sets are specially designed to provide automatic supply to multiple hose reel or sprinkler outlets for firefighting installations. Pump sets combine parallel duty diesel and electric powered supply pumps to ensure serviceability in all conditions as well as a jockey pump to maintain system pressure. Particular features include:-

- Individual electric motor and diesel engine powered pump sets providing standby supply in the event of electrical power failure
- Separate automatic jockey pump to maintain system pressure and regulate main pump operation
- Bellows type pressure switch controlled operation providing progressive jockey pump, electric pump and diesel pump starting at reducing cut-in pressures
- Low maintenance diaphragm type pressure vessel to regulate the jockey pump cycling.
- Integral control panel providing automatic parallel operation of the supply pumps and incorporating electrical protection panels and a DC battery charging system
- Compact frame mounted design incorporating necessary valves and piping for simple site installation

Systems are designed to give rated output of either about 5bar or 10bar and six standard sizes are available 10,20,40,60,100 and 120m<sup>3</sup>/hr with the two pump sets operating in parallel, 50% standby output being provided in the event of electrical failure.

Fire sets EN 12845 specification certified as compliant by KEBS are also available. Performance and design is similar though some components are to high level specification as stipulated in the standard.

Dayliff FLA Fire Sets combine quality components for optimal operational efficiency with Dayliff unmatched pumping expertise and competitive pricing to provide effective, reliable and easy to install firefighting solutions.

## SPECIFICATIONS

**Supply Pumps:** Dayliff DE end suction bareshaft or DMS horizontal multistage centrifugal pumps featuring gland packing seal and heavy duty cast iron construction. DE pumps have bronze impellers while DMS pumps have cast iron stage, impellers and diffusers. Pump models are selected to meet the design pressure and flow rates. Detail performance curves are available on request.

**Diesel Engine:** Options of Dayliff DLA air cooled or Dayliff DLY water-cooled with automatic electric start. Alternative engines are available on request.

**Electric Motor:** TEFC squirrel cage 2-pole 2900 rpm electric motors suitably rated for the pump load.

**Jockey Pump:** Option of DB4-60 horizontal multistage pump or Dayliff DIN 3-19 vertical multistage centrifugal pump fitted with electric motor. The pump is set to maintain system pressure at 10bar thus avoids cycling of the service pumps due to minor system leakages.

**Pressure Vessel:** GWS pressure vessel featuring polypropylene liner with special diaphragm and air valve design that eliminates leaks and the need for maintenance.

**Piping:** Suitably sized piping and fittings are provided for direct suction and delivery line connections including necessary isolating gate valves, non-return valves on the system outlet. The limit of piping is shown in the schematic drawing.

**Control Panel:** Electric pump control panel with star-delta starter, Jockey pump control panel with DOL starter and engine pump control panel with DC power circuit for engine and DC battery charging system. The control panels are integrally mounted as standard though can be supplied loose for remote installation if required.

## EQUIPMENT SPECIFICATION

Model	Nominal Flow (m <sup>3</sup> /hr)		Medium Pressure 5Bar				Wt (kg)	Model	High Pressure 10Bar				Piping DIA (")	
			Electric Pump		Diesel Pump				Electric Pump		Diesel Pump			
	Parallel Duty	Single Duty	Pump	Motor (kW)	Engine	Power (kW)			Pump/Impeller Dia	Motor (kW)	Engine	Power (kW)		
<b>FLA 10/5</b>	10	5	DE 32-16	5.5	DLA10DE	6	420							2
<b>FLA 20/5</b>	20	10	DE 32-20	7.5	DLA20D	8	450							
<b>FLA 40/5</b>	40	20	DE 32-20	7.5	DLA20D	13	570	<b>FLA 40/10</b>	DE40-32H/272	30	DLY40	29	690	4
<b>FLA 60/5</b>	60	30	DE 40-20	11	DLA20D	13	600	<b>FLA 60/10</b>	DE40-32H/280	30	DLY60	42	990	
<b>FLA 100/5</b>	100	50	DE 50-20	15	DLY40	29	805	<b>FLA 100/10</b>	DE40-32H/310	37			1100	
<b>FLA 120/5</b>	120	60	DE 65-20	30	DLY60	42	900	<b>FLA 120/10</b>	DE50-32H/285	45	DLY80	62	1420	6