



# Domestic Reverse Osmosis Unit



# Installation & Operating Manual



# INDEX

<b>1. SPECIFICATIONS</b>	1
<b>2. WARNINGS AND SYMBOLS</b>	2
<b>3. INSTALLATION</b>	5
<b>4. OPERATION AND MAINTENANCE</b>	12
<b>5. MAINTENANCE</b>	13
<b>6. TROUBLE SHOOTING</b>	15
<b>7. TERMS OF WARRANTY</b>	16

**Congratulations on selecting a Dayliff Domestic Reverse Osmosis Purifier. They are manufactured to the highest standards and if installed and operated correctly will give many years of efficient and trouble free service. Careful reading of this Installation Manual is therefore important, though should there be any queries they should be referred to the equipment supplier.**

## 1. SPECIFICATIONS



A six stage water treatment purifier suitable for clean water from municipal sources for under sink installation that includes:

- Three stage sediment and carbon cartridge pre-treatment
- Compact reverse osmosis purification using Hidrotek/Filmtec membranes
- Ultra violet sterilizer and carbon filter post treatment
- 10L steel storage tank
- Sink mounted output tap
- Daily outputs of 200L/day and 400L/day are available, Chlorine Level <0.2ppm, TDS <250ppm, Water Temperature 5-45°C, Inlet Water Pressure 1-3bar

### TECHNICAL SPECIFICATIONS

**Voltage and Frequency:** 110V-240V 50Hz/60Hz

**Wattage:** 25W-36W

**RO Element Capacity:** 50/100 GPD

**Tank Capacity :** 3.2G Steel or 3.0G Plastic

**Inlet TDS:** ≤ 250ppm

**Chlorine Level:** ≤ 0.2ppm

**Average RO Rejection Rate:** 98%

**Inlet Water Pressure (Min/Max):** 1 - 3Bar

**Inlet Water Temperature (Min/Max):** 5°C - 45°C

**Flush Type (model dependent):** Auto

The stages and their functions are outlined below;

- **First Stage: Spun PP Filter** - removes larger particles suspended in water.
  - **Second Stage: Granular Carbon Filter** - removes any organics, chlorine, odor and turbidity
  - **Third Stage: Block Carbon Filter** - further removes any organics, chlorine, odor and turbidity that may have passed 2<sup>nd</sup> stage.
  - **Fourth Stage: RO Membrane** - removes bacteria, heavy metals, dissolved matter and salinity.
  - **Fifth Stage : Inline Carbon Filter (post filter)** - adjust the taste of treated water.
  - **Sixth Stage: Mineralised Ball Filter** - reincorporates healthy minerals back in to treated water.
- Ultraviolet Sterilizer** - kills any bacteria, virus or organisms present in water.

### PACKAGE CONTENTS

1. Reverse Osmosis Unit - 1 pcs
2. Housing Wrench - 1 pcs
3. Food Grade Tubing - 4pcs (red, white, yellow and blue)
4. Faucet - 1 pcs
5. Accessories - tube plug, screws, drain clamp, tee fitting, ball valve and feed water valve
6. RO Membrane - 1 pcs
7. Manual - 1 pcs

## 2. WARNINGS AND SYMBOLS



*The system should not be turned on/off by pulling the power plug as it may cause a fire.*



*Electrical connections, maintenance and repairs must be done by a qualified electrician in accordance with local regulations.*



*The purifier is intended for potable water only. Where water quality is not guaranteed pre treatment may be required.*



*In the event that the power cable is destroyed, it must be replaced with a similar kind.*



***The unit must not be immersed in water.***



***Ensure source water pressure is between 1-3 bar. If source water pressure exceeds maximum pressure, a pressure reduction valve may be needed.***



***When cleaning the unit, the power cord should be disconnected from the power source.***



***When not in use all the water should be drained out and power supply disconnected.***



***In the event of water leakage, the water and power supply should be disconnected to avoid equipment damage or personal injury.***



***All tubing must be well secured to avoid water splashing. Improper connections may cause leaks from the fitting.***



***This appliance is intended to operate and function as per the instructions in this manual. It is not designed to operate outside of the specifications listed and any attempt to do so or tampering with the unit can cause damage to the unit and/ or bodily harm.***



***Ensure source water temperature is between 5°C-45°C. System will not function properly if these temperatures are exceeded.***



***Waste water should be drained properly in line with local regulations.***

## TREATMENT PROCESS

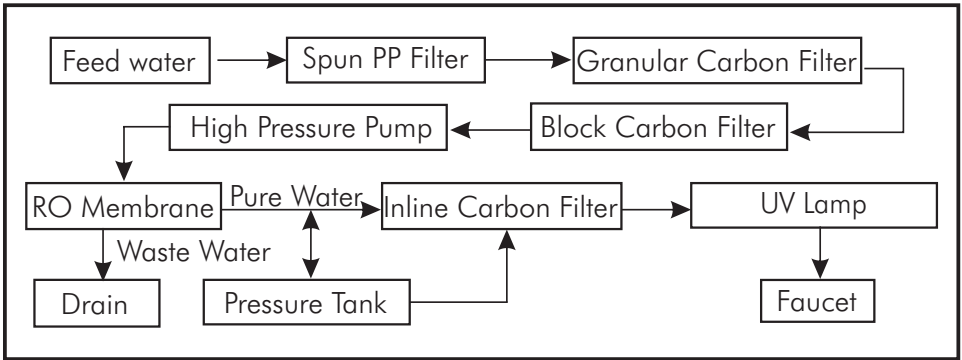

## SYSTEM COMPONENTS

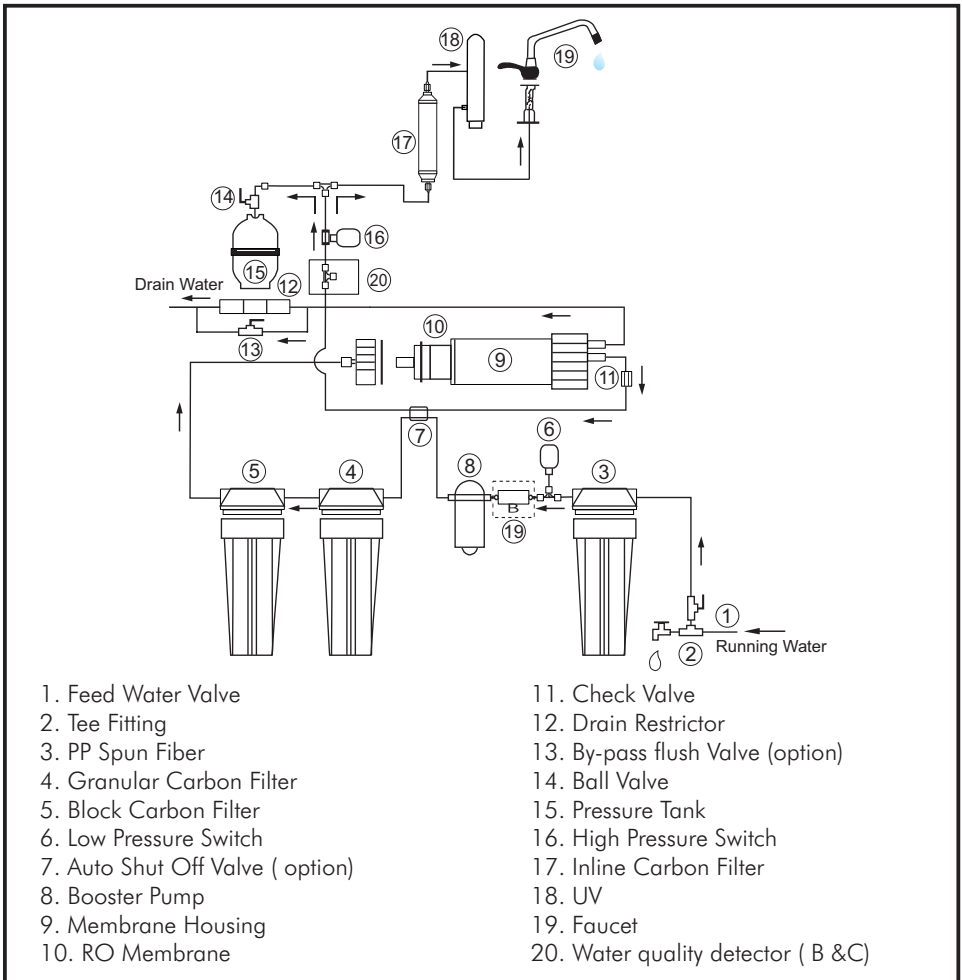

### 3. INSTALLATION



*All the joints and screw thread should be wrapped with seal tape to avoid water leakage.*



**Knife**



**Electric Drill**



**Seal Tape**



**Hammer**



**Monkey Wrench**



**Scissors**



**Faucet**



**Tank**



**Housing Wrench**

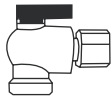

**Tank Ball Valve**

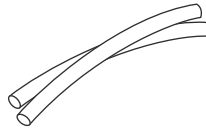

**Water Pipe**



**Clip**

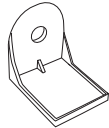

**Faucet Bracket**



**RO Membrane**



**Manual**



**Feed Water Valve**

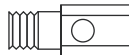

**Tee Fitting**

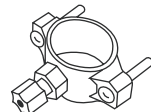

**Drain Clamp**

## UNIT PLACEMENT

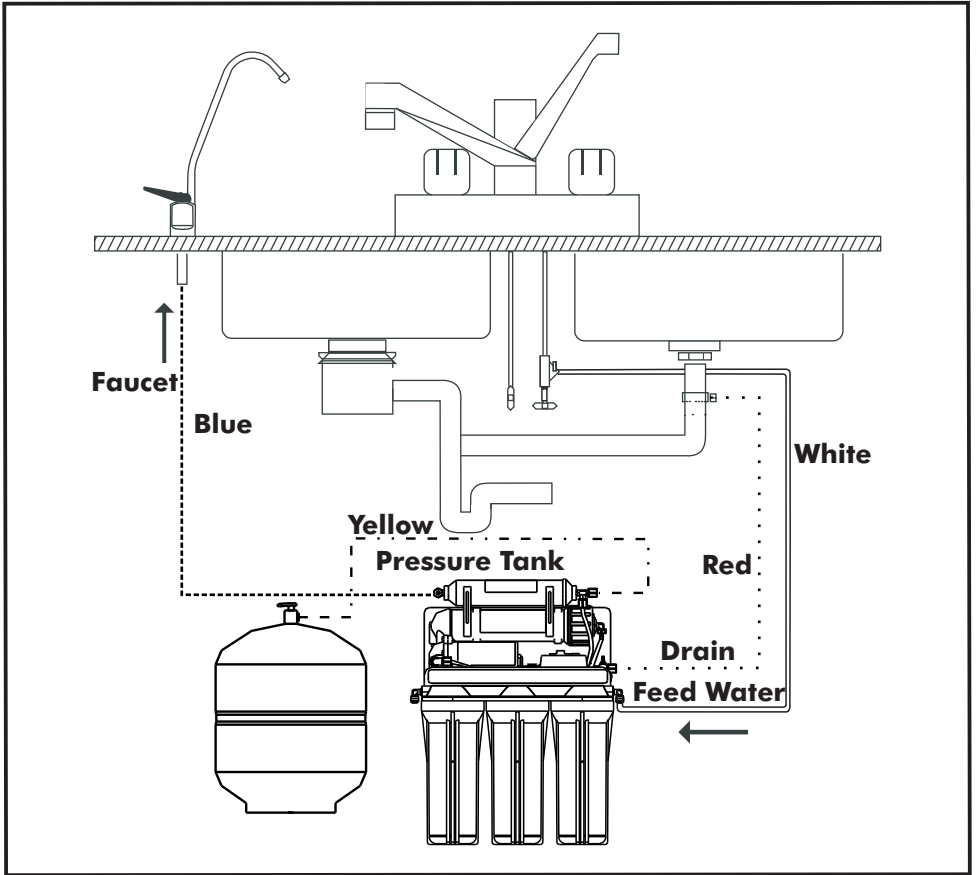

- The unit can be placed flat or upright and on top, inside, or under the cabinet. Feed Water connection should be as close as possible to unit. However, if due to space or other limitations, this unit can be placed where it is convenient.
- When choosing a location for the unit, remember to have easy access to cold water line, drain pipe, power outlet, and enough room to change filters.

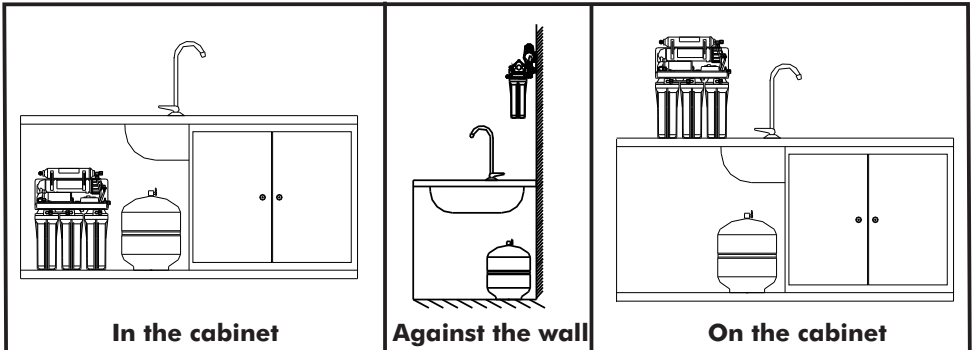

## Install the Feed Water Valve

- Install the feed water valve tee fitting and then connect to source water.



**The water supply to the unit must be from cold water line.**

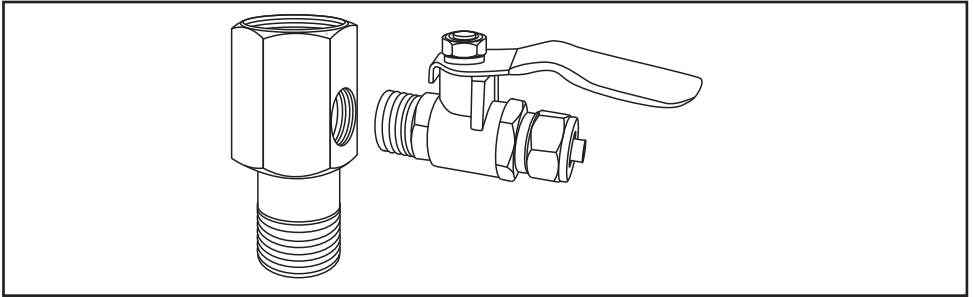

**Use only a cold potable water supply as feed water. Hot water will damage the unit. Softened feed water will extend the life of the RO Membrane.**

## Feed Water Valve and Tee Fitting

- Install tee fitting and feed water valve as per diagram.
- Wrap threads of feed water valve and tee fitting with teflon tape.
- Connect white feed water tubing from unit to feed water valve.

## Tube Connection

- Refer to the following diagram for how to properly install the Quick fittings and JACO fittings.

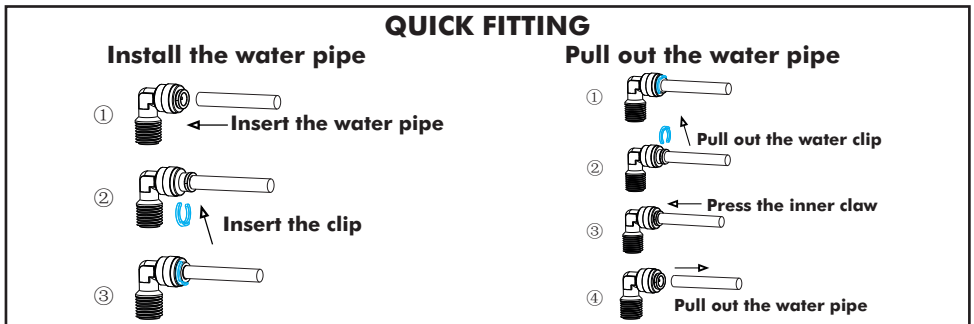

## JACO FITTING

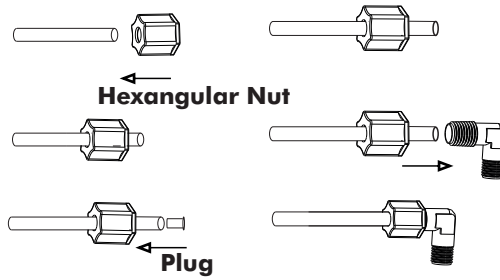

**All components and tubing should be located in an area not exposed to direct sunlight.**

### Drain Clamp Installation

- Position drain clamp on drain pipe above the drain trap and tighten securely.
- Using the drain clamp as a guide, drill a 6mm hole, enough for the 1/4" tubing to pass, through one side of the drain pipe. **DO NOT drill through both sides.**
- Connect **Red Waste Water Tubing** from unit to Drain Clamp.



**When cutting the tubing make clean square cuts, failing to do so result in poor connection and possible leaks.**



**The lowest point of the line should be the point of connection to the Drain Clamp. There should be no sag in the line as this may cause excessive noise as the reject water is flowing to drain.**

## DRAIN CLAMP ASSEMBLY

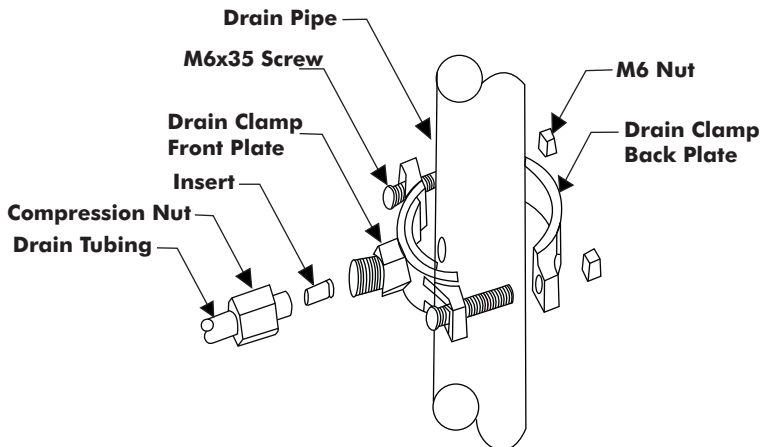

## Pressure Tank

- Keep Pressure Tank within 3m of faucet.
- If longer length of tubing is needed, use 3/8" tubing to prevent pressure drop.
- Tank can weigh up to 14kgs when full, ensure it is set on firm and level flooring.
- Install ball valve by screwing valve on to tank and apply teflon tape to prevent leaking.
- Connect yellow tubing from post filter to pressure tank.

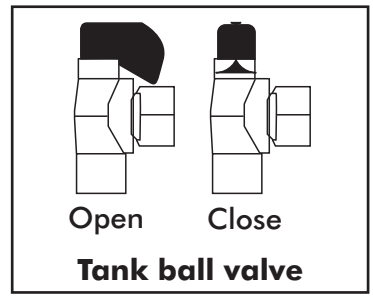

## Install Tank

- Connect shut-off valve to the tank
- Then connect yellow tubing from tank to the post filter cartridge.

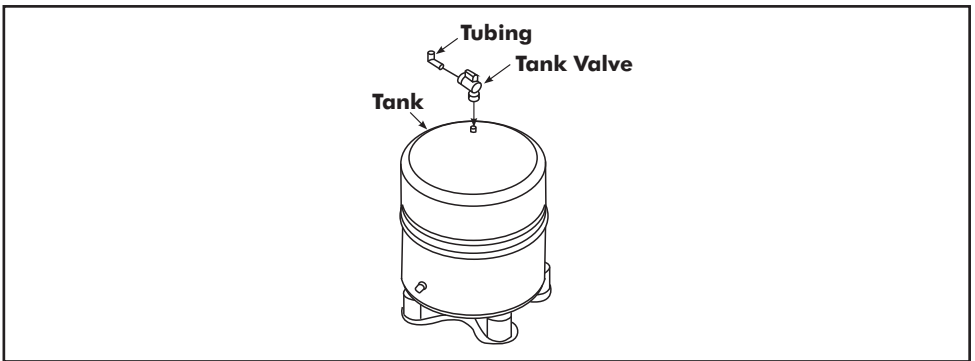

## Faucet Installation

- Select a convenient location near the sink to place the faucet.
- Drill a hole 12mm in diameter in counter top.
- Place washers, plates, seals and nuts in order as per diagram and tighten on to counter.
- Attach Blue Pure Water tubing to the bottom of faucet and connect tubing to unit.

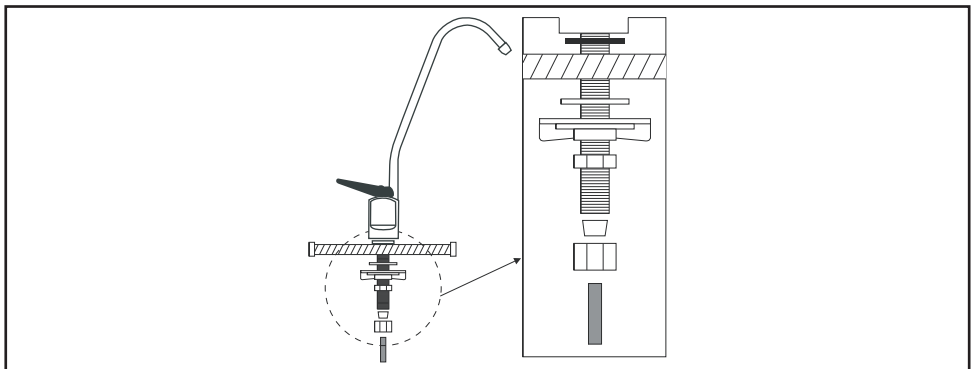



**Check that tubing is connected correctly according to connection diagram.**

### Install Pre-Filters

- Remove pre-filters from packaging.
- Place filters in appropriate housings according to labels and install filter housing from right to left in the following order: PP, GAC, CTO. Tightening housings with wrench provided.

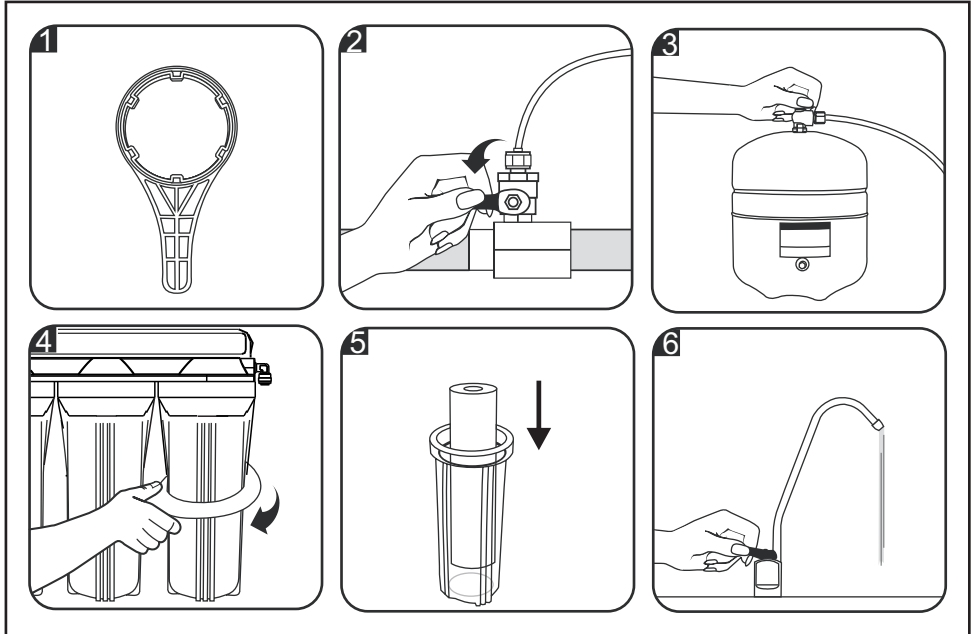

**When installing housings make sure housing is level and even to avoid leaking.**





### Install RO Membrane Element

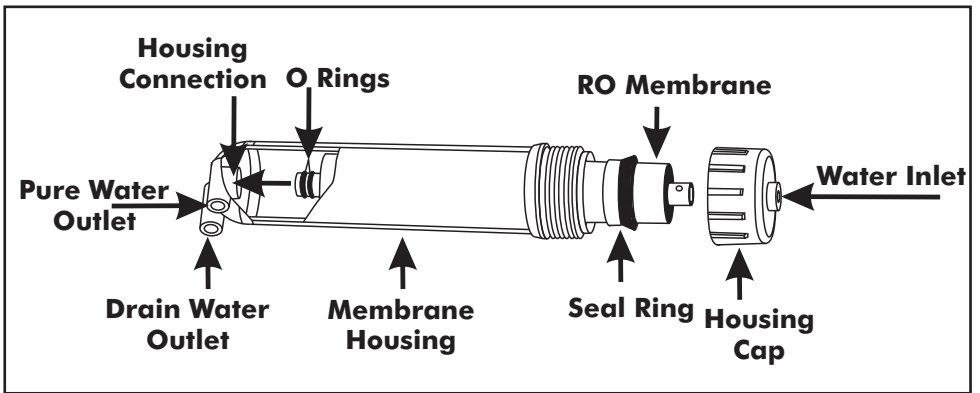

**Before proceeding with membrane element installation, flush pre-filters thoroughly.**

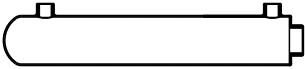

### Install Ultraviolet Sterilizer

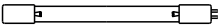
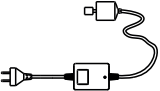
<p><b>1. UV Chamber</b></p>	
<p><b>2. Glass Tube</b></p>	
<p><b>3. Aluminum Nut</b></p>	
<p><b>4. Silicone Stopper</b></p>	
<p><b>5. Silicone Seal</b></p>	
<p><b>6. UV Lamp</b></p>	
<p><b>7. Adaptor</b></p>	

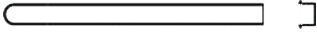
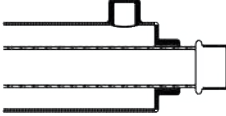
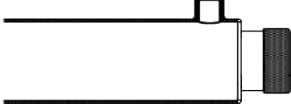
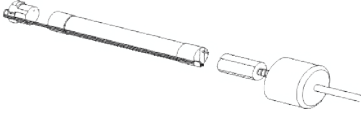
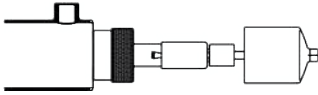
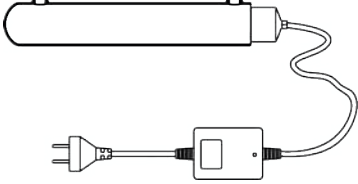
<p>Step 1: Place The <b>Silicone Stopper</b> and <b>Silicone Seal</b> ( Item 4 and 5 ) at the tip of <b>Glass Tube</b> ( Item 2 ).</p>	
<p>Step 2: Slide-in the <b>Glass Tube</b> ( Item 2 ) into the <b>UV Chamber</b> ( Item 1 ).</p>	
<p>Step 3: Fasten the <b>Aluminum Nut</b> ( Item 3 ) to seal the <b>UV Chamber</b> ( Item 1 ).</p>	
<p>Step 4: Plug the <b>Adaptor</b> ( Item 7 ) to the <b>UV Lamp</b> ( Item 6 ).</p>	
<p>Step 5: Insert the <b>UV Lamp</b> ( Item 6 ) into the <b>UV Chamber</b> ( Item 1 ).</p>	
<p>Step 6: Seal it up with the Rubber Stopper that is already attached to the <b>Adaptor</b> ( Item 7 ).</p>	



***Do not look at the ultraviolet rays emitting out of the UV lamp without protection since they cause serious damage to naked eyes.***

## 4. OPERATION

### **Pre-filter Flushing (initial setup, before installing RO Element)**

Prepare system for operation by flushing pre-filters:

- Disconnect RO element inlet tube on element housing cap. Open water main and inlet valve and allow system to run through the 3 pre-filters.
- Discard output water into container or drain.
- Continue flushing until output water is visibly clean. Reconnect tube.



***Pump and membrane may be severely damaged if system is run without flushing pre-filters. Discard all water from flush, it is not suitable for consumption.***

- After flushing pre-filters connect and open all valves.
- Wait approximately 2 minutes before opening the faucet.
- Allow system to flush for first 10-15 minutes with faucet open. Do not use water from RO unit at this time.

### Flushing the Pressure Tank

- After flushing the Pre-Filters, allow the unit to operate and fill the pressure tank.
- Tank will take approximately 3.5 hours to fill. Once tank is full, discharge pressure tank by leaving faucet open.
- Once tank is completely empty, close faucet and allow tank to fill again.
- After the pressure tank has been flushed, the unit is ready for use.

### Regular Operation

- Once system has been set up and plugged into a power source, it will operate automatically when the faucet is open. Once the faucet is closed, the unit will switch off automatically. After use, the unit will flush automatically.

## 5. MAINTENANCE

### Filter Replacement

- Close feed water valve.
- Close tank ball valve on pressure tank.
- Open faucet and drain any remaining water from system.
- Disconnect quick connect filters.
- Replace filters, reconnect, and open valves.
- Perform pre-filter flush after filters have been changed.

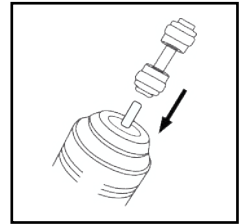

### Membrane Replacement

- Close Feed Water Valve.
- Close Tank Ball Valve on Pressure Tank.
- Open Faucet and drain any remaining water from system.
- Open membrane housing and remove used membrane.
- Follow the same procedure as RO membrane installation to replace RO membrane.

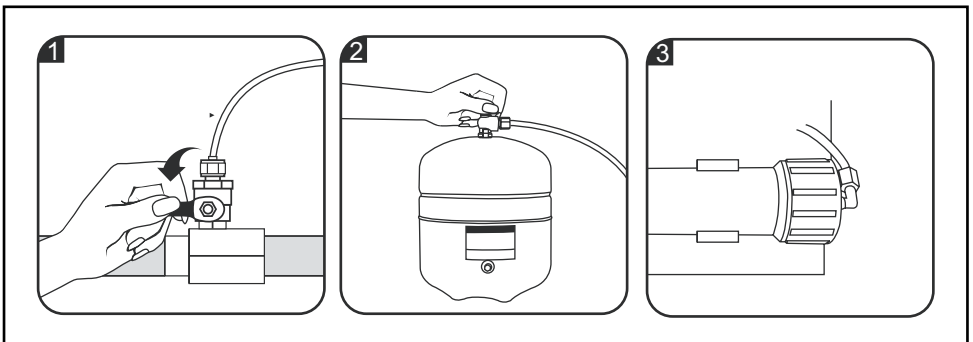

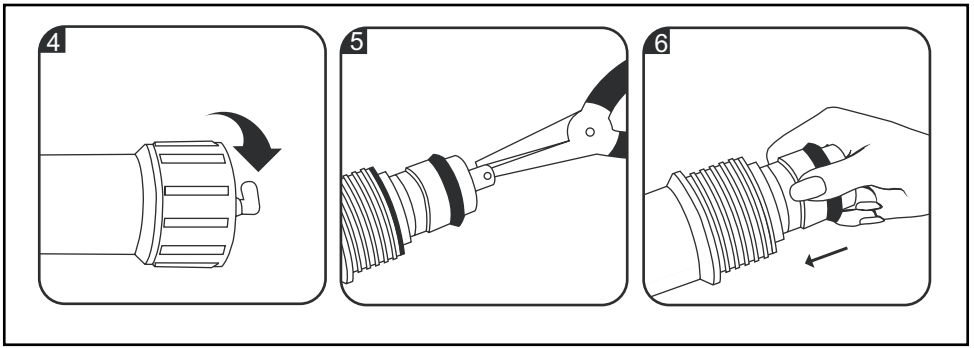

## System Maintenance

To ensure the unit operates at its optimum level, routine maintenance is required. The frequency of maintenance depends on the feed water quality and amount of system usage. The following are some guidelines for scheduled filter changes, keep in mind the frequency of filter changes may vary. If in doubt, contact equipment supplier.

- Change Spun PP Filter every 3-6 months or as required.
- Change Spun PP Filter every 3-6 months or as required.
- Change RO Membrane every 18-24 months or as required.
- Change Inline Carbon Filter every 6-12 months or as required.

When the unit is not in use for an extended period of time, disconnect it from power supply. Before resuming use, perform the same flushing procedure as in the initial set up.

## 6. TROUBLE SHOOTING

PROBLEM	POSSIBLE CAUSE	SOLUTION
No water being produced	Water source is off	Turn on feed water
Not enough water being produced	Blocked water supply	Unblock the supply pipe
	Feed water valve is closed	Open the valve
	No drain flow	Clean or replace the check valve
Pump not running	Low feed water pressure	Check water pressure
	No power supply	Turn on power
	Transformer burnt out	Replace transformer
Pump is running but system is not producing water	Pre filters clogged	Replace filter cartridges
	Inlet solenoid valve not working	Repair or replace the valve
System does not shut off	Auto shut off switch not working	Repair or replace switch
Abnormal pump noise	Pre filters clogged	Replace filter cartridges
	Low feed water pressure	Adjust feed water pressure
No drain water	Clogged drain flow restrictor	Replace the drain flow restrictor
Tubing leaks	Tubing connection incorrect	Check or reinstall tubing
	Defective or damaged tubing	Replace section of tubing

## 7. TERMS OF WARRANTY

### i) General Liability

- In lieu of any warranty, condition or liability implied by law, the liability of Dayliff in respect of any defect or failure of equipment supplied **is limited to making good by replacement or repair** (at the Company's discretion) defects which under proper use appear therein and arise solely from faulty design, materials or workmanship within a specified period. This period commences **immediately after the equipment has been delivered to the customer** and at its termination all liability ceases. Also the warranty period will be assessed **on the basis of the date that the Company is informed of the failure.**
- **The warranty applies solely to equipment supplied and no claim for consequential damages**, however arising, will be entertained. Also the warranty specifically excluded defects caused by fair wear and tear, the effects of careless handling, lack of maintenance, faulty installation, incompetence on part of the equipment user, Acts of God or any other cause beyond the Company's reasonable control. Also, any repair or attempt at repair carried out by any other party **invalidates all warranties.**

### ii) Standard Warranty

If equipment failure occurs in the normal course of service having been competently installed and when operating within its specified duty limits warranty will be provided as follows:-

- **Up to 1 year - The item will be replaced or repaired at no charge.**
- **Over 1 year, less than two years - The item will be replaced or repaired at a cost to the customer of 50% of the Davis & Shirtliff market price.**

The warranty on equipment supplied or installed by others is conditional upon the defective unit **being promptly returned free to a Davis & Shirtliff office** and collected thereafter when repaired. No element of site repair is included in the warranty and any site attendance costs will be payable in full at standard chargeout rates. Also proof of purchase including the purchase invoice must be provided for a warranty claim to be considered.

**DAYLIFF** is a brand of **Davis & Shirliff**

for enquiries contact

**Davis & Shirliff, Ltd.**

P.O. Box 41762 - 00100, Nairobi, Kenya

Tel: 6968000/ 0711 079 000

or visit

**[www.davisandshirliff.com](http://www.davisandshirliff.com)**

for details of the nearest branch or stockist