

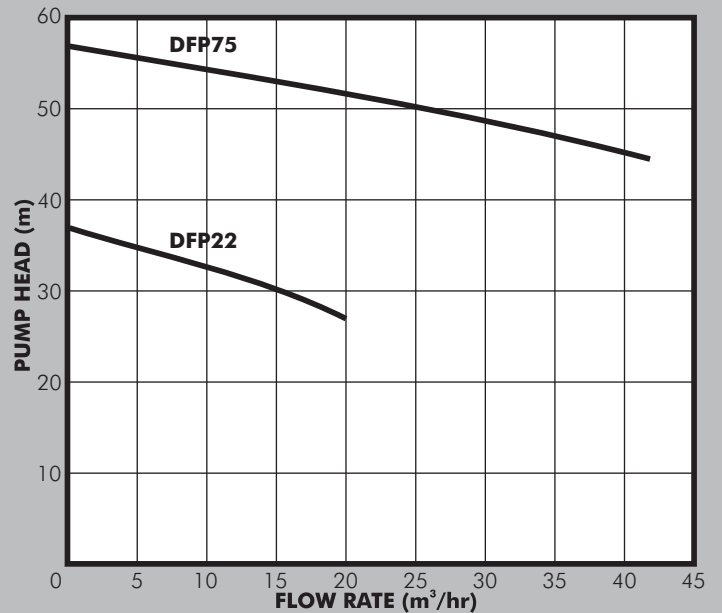

# DFP Sanitary Pump

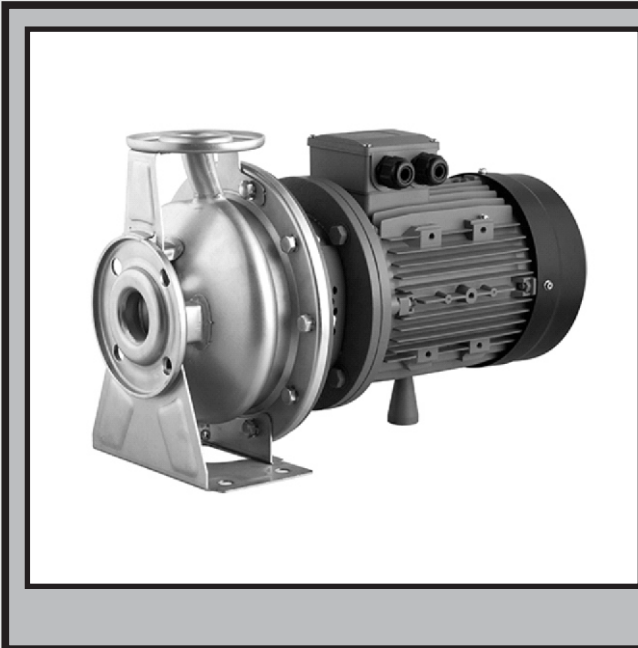

### PUMP

Dayliff DFP sanitary pumps are of single stage centrifugal impeller specifically designed to meet the hygiene requirements of sterile operating processes. They are suitable for various applications including water supply systems, pressure boiler feeding, pure water treating systems, pharmaceutical, food and refining chemical industries. The design features optimised hydraulics for high efficiency and polished internal finishes to prevent fouling by bacteria and germs. Pump hydraulic end construction is AISI 316L stainless steel throughout with specialised mechanical seal that can handle hot pumped media.

### MOTOR

Pumps are close coupled to reliable TEFC electric motors designed for continuous duty. Single phase motors have integral thermal protection and can be connected directly to the mains power through a 10A fuse or MCB. Three phase motors require a remote DOL starter.

**Enclosure Class:** F

**Insulation Class:** IP57

**Speed:** 2900rpm

### OPERATING CONDITIONS

**Pumped Liquid:** Low viscosity fluids with a max. viscosity of 150mm<sup>2</sup>/s

**Maximum Operating Pressure:** 10 bar

**Maximum Temperature :** 110°C

### PUMP DATA

Model	Motor		Current (A)	Voltage (V)	DNA (")	DNM (")	Dimensions (mm)					Weight (kg)
	kW	HP					W	H	L	D2	D1	
<b>DFP22</b>	2.2	3	5	1x240	50	32	244	292	472	165	140	32
<b>DFP75</b>	7.5	10	15	3x415	65	40	300	340	535	185	150	67

