

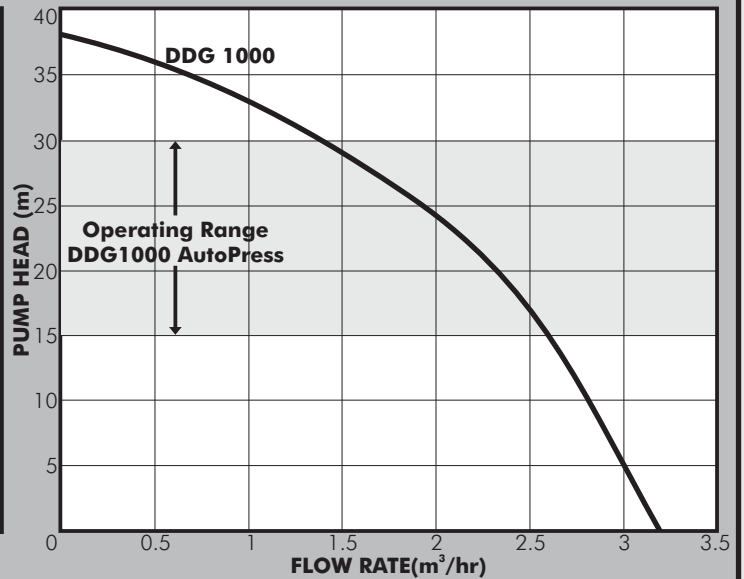

DDG
Centrifugal
Booster Pump

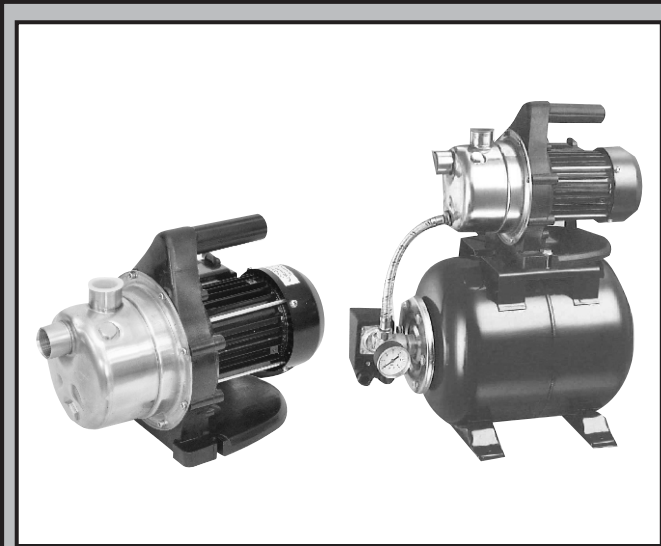

PUMP

The DAYLIFF DDG pump is of single stage centrifugal impeller self priming design suitable for small scale irrigation, water boosting and water transfer applications. Materials of construction are stainless steel for the pump body, shaft and back plate with the impeller made from polypropylene. The pump is provided with a handle for easy portability, priming screw and a drain plug.

Also available is the 'AutoPress' automatic booster system which incorporates a 19L horizontal diaphragm tank, pressure switch and pressure gauge for automatic pump operation.

MOTOR

Pumps incorporate a TEFC motor with built-in thermal overload protection. The motor can be connected to mains electrical supply through a 10A fuse or MCB, though additional protection is recommended where there is risk of voltage fluctuation.

Enclosure Class: X4 **Insulation Class:** B **Voltage:** 1x240V **Speed:** 2900rpm

OPERATING CONDITIONS

Pumped Liquids: Thin, slightly aggressive liquids without solids or fibres

Max. Liquid temperature: +35°C

Max. Ambient temperature: +40°C

Max. Suction Lift: 6m at sea level

AutoPress: Cut-in Pressure - 1.5 bar, Cut-out Pressure 3 bar

PUMP DATA

Model	Motor		Current (A)	DN1 (")	DN2 (")	Dimensions (mm)			Weight (kg)
	kW	HP				H	L	W	
DDG 1000	0.8	1	2.5	1	1	244	336	201	7
DDG 1000 AutoPress						463	570	280	12

