



DDF
Fountain Pumps



Installation &
Operating Manual

INDEX

1. PUMP SPECIFICATIONS	1
2. OPERATION & MAINTENANCE	2
3. SAFETY REGULATIONS	2
4. PUMP EXPLODED DIAGRAM	3
5. WARRANTY	4

Congratulations on selecting a Dayliff DDF Pump. They are manufactured to the highest standards and if installed and operated correctly will give many years of efficient and trouble free service. Careful reading of this Installation Manual is therefore important, though should there be any queries they should be referred to the equipment supplier.

1. PUMP SPECIFICATION

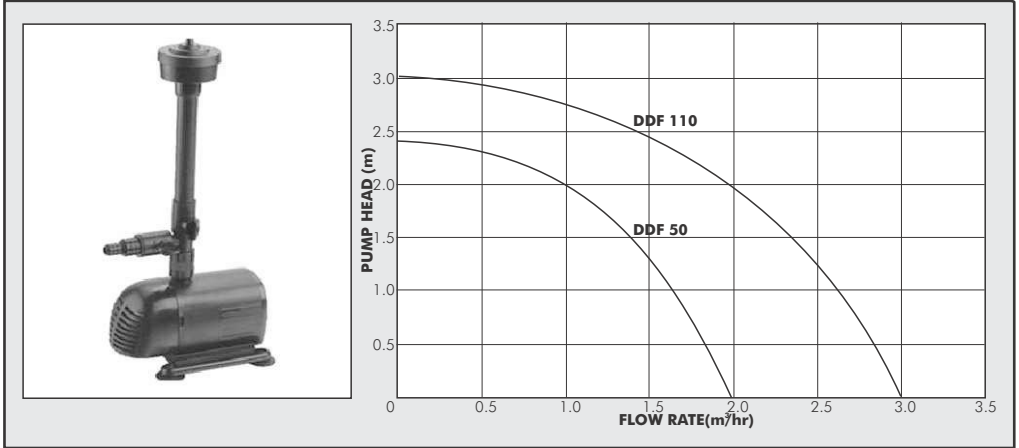

Pump

The DAYLIFF DDF fountain pumps are designed for all applications involving the creative use of water. They include a number of features as follows;

- Pumps are provided with a corrosion proof plastic housing with easy clean foam pre-filter.
- High output pump with specially designed impeller for improved solids handling capacity
- Telescopic output tube with valve for spray adjustment and waterfall outlet.
- Supplied complete with various display jets for different display option and a 10m cable.

The fountain pump offer the benefits of various display options powered by a robust and efficient pump and are ideal solutions for all small scale fountain displays and garden water features.



Foaming Jet

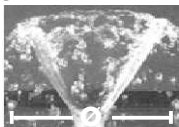

Inverted Cone

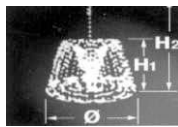

Double Stage

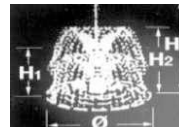

Triple Stage



Bell

Pump Data

Model	Power (W)	Current (A)	Outlet (")	Dimensions (mm)				Wgt (kg)	Foaming Jet	Inverted Cone	Double Stage			Triple Stage				Bell
				H	Ø	H1	H2		Ø	H1	H2	H3	Ø	Ø				
DDF 50	50	0.37	½	375	120	170	126	2	12	N/A	50	110	190	30	55	75	150	32
DDF 110	110	0.62	1	670	178	200	138	4	14	35	N/A			30	50	70	100	N/A

Jet dimensions in cm

2. OPERATION & MAINTENANCE

Features

- Compact construction.
- This pump should be operated in accordance with the safety regulations.
- Place directly into water for operating fountains and other water features.
- Place the pump on a horizontal surface, slightly elevated from the bottom to prevent the pump from becoming excessively muddy.
- The pump should never be run dry without water.
- Dirt removal via pre-filter.
- To clean the filter sponge; first remove the intake sieve and then remove the sponge from the pump body.
- Rinse filter in lukewarm water to remove deposits.
- Insert the filter sponge and place the intake sieve.
- The pump should remain in water at all times. Turn the pump on occasionally to prevent malfunction due to sedimentation

3. SAFETY REGULATIONS

- Do not operate when cable or housing appear to be defective.
- Do not use the pump with power networks, extension cables or adapters without proper earthing.
- Ensure electric power supply corresponds to specifications on the name plate.
- Do not pull, carry or hang up by the cable.
- Before any maintenance is carried out; turn off the power source and all electric appliances connected via the water. The pump should not be used in chlorinated water, acidic or alkaline solutions as this will affect the cable durability.
- Electrical connections must comply with local regulations and the pump should be supplied with an isolator and connected to mains power through a fuse or MCB.

4. PUMP EXPLODED DIAGRAM

1. Wire Plug
2. Nameplate
3. Back Cover
4. Underframe
5. Main Body
6. Output Connector
7. Output Tube
8. Waterclock Sprinkle System
9. Waterfall Sprinkle System
10. Rotor
11. Propeller Cover
12. O-type Sealing Washer
13. Plastic Filter
14. Filter Cover
15. Tee Fitting System
16. Waterfall Sprinkle System

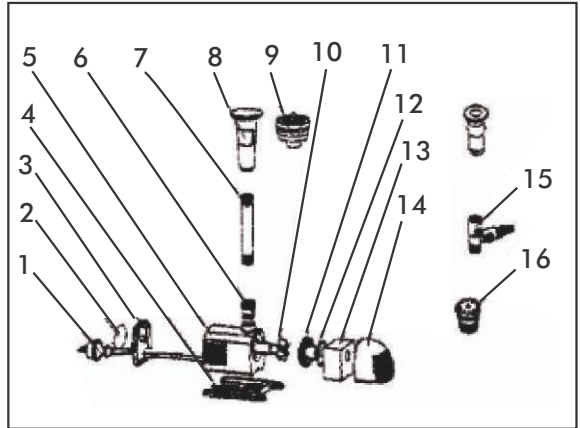

5. TERMS OF WARRANTY

i) General Liability

- In lieu of any warranty, condition or liability implied by law, the liability of Davis & Shirliff (hereafter called the Company) in respect of any defect or failure of equipment supplied **is limited to making good by replacement or repair** (at the Company's discretion) defects which under proper use appear therein and arise solely from faulty design, materials or workmanship within a specified period. This period commences **immediately after the equipment has been delivered to the customer** and at its termination all liability ceases. Also the warranty period will be assessed **on the basis of the date that the Company is informed of the failure**.
- This warranty applies solely to equipment supplied and **no claim for consequential damages**, however arising, will be entertained. Also the warranty specifically excludes defects caused by fair wear and tear, the effects of careless handling, lack of maintenance, faulty installation, incompetence on the part of the equipment user, Acts of God or any other cause beyond the Company's reasonable control. Also, any repair or attempt at repair carried out by any other party **invalidates all warranties**.

ii) Standard Warranty

General Terms

If equipment failure occurs in the normal course of service having been competently installed and when operating within its specified duty limits warranty will be provided as follows:-

- **Up to 1 years - The item will be replaced or repaired at no charge.**
- **Over 1 years, less than two years - The item will be replaced or repaired at a cost to the customer of 50% of the Davis & Shirliff market price.**

The warranty on equipment supplied or installed by others is conditional upon the defective unit **being promptly returned free to a Davis & Shirliff office** and collected thereafter when repaired. No element of site repair is included in the warranty and any site attendance costs will be payable in full at standard chargeout rates. Also proof of purchase including the purchase invoice must be provided for warranty claim to be considered.

DAYLIFF is a brand of **Davis & Shirliff**

for enquiries contact

Davis & Shirliff, Ltd.

P.O. Box 41762 - 00100, Nairobi, Kenya

Tel: 6968000/ 0711 079 000

or visit

www.dayliff.com

for details of the nearest branch or stockist