

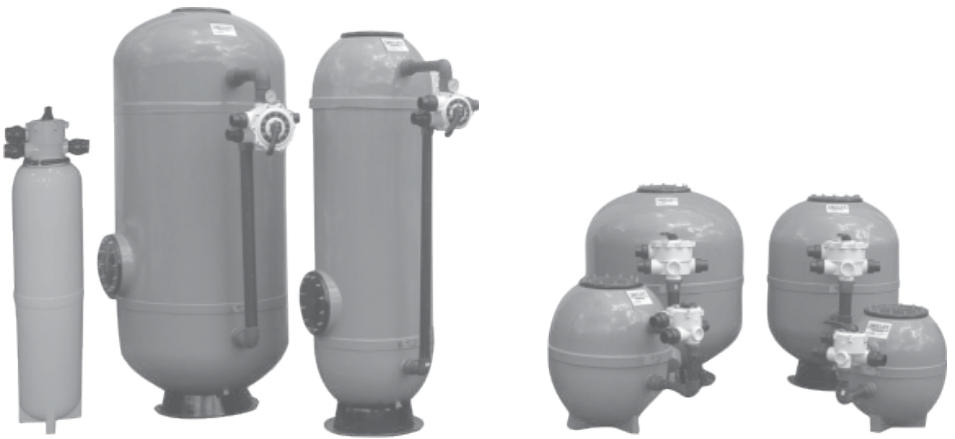

CX Filter



DEEP BED

STANDARD BED

Installation & Operating Manual

INDEX

1. SPECIFICATIONS	1
2. INSTALLATION	3
3. OPERATION	9
4. TROUBLE SHOOTING	12
5. TERMS OF WARRANTY	13

Congratulations on selecting a Dayliff CX Filter. They are manufactured to the highest standards and if installed and operated correctly will give many years of efficient and trouble free service. Careful reading of this Installation Manual is therefore important, though should there be any queries they should be referred to the equipment supplier.

1. FILTER SPECIFICATIONS

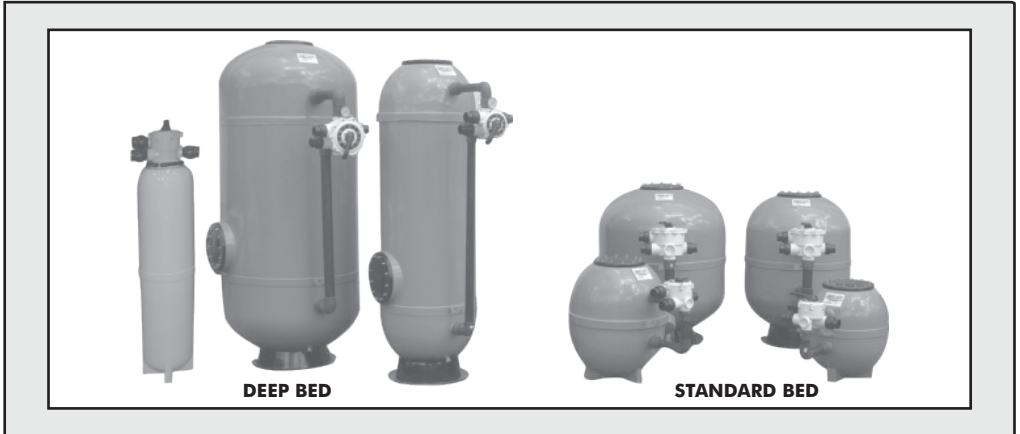

The DAYLIFF 'CX' filter range of industrial specification filters have been specially developed for institutional and commercial applications where higher levels of operating performance and reliability are demanded. Their design combines leading filter technology with many years of GRP production experience and the result is a range of quality products suitable for both swimming pools and general water treatment uses. Features include:-

- Wide range of four diameters with Deep Bed options in 600 and 900 sizes for specialised water treatment applications.
- Available in standard and high pressure.
- All plastic non-corroding construction throughout including an exceptionally strong GRP filter body making 'CX' filters especially suitable for corrosive and aggressive waters.
- Heavy duty bolted GRP access cover secured by twelve stainless steel studs with 200mm aperture providing ease of access for media charging and removal. Deep Bed models also feature a low-level side mounted cover to facilitate media removal and general internal maintenance.
- Wide 100mm bottom outlet for filter drainage and media removal (CX 800 and 900 models).
- Option of simple to use multiport valves or manifold mounted 'Novasfer' full way ball valves for simplified flow control.

- Automatic air-bleed system.
- High efficiency internal flow arrangement to ensure even filtration and effective backwash flows.

For swimming pools applications DAYLIFF 'CX' filters can be used either individually or, for large water volumes, by combining a number of units in parallel. For water treatment applications DAYLIFF 'CX' filters are suitable for various medias including silica sand anthracite and glass media for sediment removal with the Deep Bed models being particularly suitable for activated carbon for taste, odour and chlorine removal, fluoride removal resin, anion resin for softening and DMI for iron removal.

DAYLIFF 'CX' filter are quality high performance products specially designed to meet the demands of the most arduous operating conditions. The combination of highly effective filtration performance with exceptional levels of reliability and durability gives the peace of mind so important for all industrial and commercial filtering applications.

OPERATING PARAMETERS

Model	Water Treatment Applications			Swimming Pool Applications				
	Rated Flow (m ³ /hr)**			Rated Flow (m ³ /hr) *		Pool Volume (m ³ for given turnover period)		
	Maximum	Standard	Optimum	Maximum	Operating	4hr	6hr	8hr
CX500	7	4	1.0	10	8	32	48	64
CX600	10	6	1.5	14	11	44	66	88
CX800	15	9	2.5	22	18	72	108	144
CX900	22	13	3.5	32	26	104	156	208
CXD300	2.5	1.5	0.5	-	-	-	-	-
CXD600	10	6	1.5	-	-	-	-	-
CXD900	22	13	3.5	-	-	-	-	-

DIMENSIONS & WEIGHTS

Model	Filter Area(m ²)	Dimensions (mm)			Outlet Sizes		Weights (Kgs)***		Pressure (Bar)	
		H	D	L	MPV	STD	Nett	Gross	Test	Operating
CX500	0.20	610	520	840	1.5"	1.25"	22	130	4.5	7.0
CX600	0.28	760	620	930	1.5"	1.5"	28	220	4.5	7.0
CX800	0.28	1090	770	1170	2"	2"	43	400	4.5	7.0
CX900	0.44	1170	925	1325	2"	2"	58	680	4.5	7.0
CXD300	0.07	1450	310	310	1.5"	1"	20	120	3.0	7.0
CXD600	0.20	2000	620	930	1.5"	1.5"	65	850	4.0	7.0
CXD900	0.64	2150	925	1500	2"	2"	100	1800	4.0	7.0

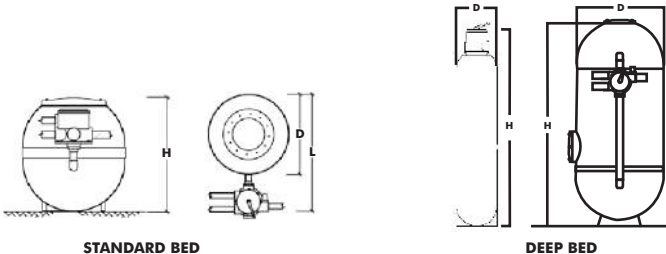

Notes

- * For swimming pool applications Maximum Rated flow is based upon a filter velocity of 50m/hr and Operating Rated flow of 40m³/hr. Suggested pool volumes are based upon the recommended Operating flow. For larger pool volumes use multiples of the given performance data to specify the number of filters required.
- ** For water treatment applications Maximum Rated Flow is based upon a filter velocity of 35m/hr and Standard Rated Flow of 20 m³/hr, though it is important that the appropriate flow rate is selected for each particular treatment process.
- ** Optimum flows are specified at 5m/hr and are ideal where maximum filtration is required e.g. for reverse osmosis applications.
- *** Nett Weight is the empty filter shell only. Gross weight includes sand media and water. Weights may be different for other media.

2. INSTALLATION

2.1 FILTER SITING

Swimming Pools

The filter plant should be sited as near to the pool as possible, a practical maximum distance of 15m being the limit. There should also be a flooded suction on the pump when the pool is full so the filter system base should be a minimum of 60 cm below top water level. For practical purposes a maximum depth of 2.5m should be used.

The filter and some pumps are waterproof and do not need special housing, though an appropriately sized mounting plinth should be prepared for the filter base. Though DAYLIFF 'CX' filters are weatherproof, an enclosed housing is recommended. The housing should be adequately ventilated and drained with at least 60 cm clearance around the filter system for accessibility.

Water Treatment

Filters should be accessible for maintenance and preferably adjacent to the components in the water treatment process.

2.2 PIPE CONNECTIONS

Swimming Pools

The recommended piping layouts for "freeboard" and "decklevel" pools are shown below. Piping should be uPVC Class C or D. Alternatively G.I. Piping can be used if there is a risk of fracture.

Pipelines should be laid with as few bends as possible and either level or at an even slope as changes in slope can lead to air pockets and consequent operational problems. The backwash pipe must fall evenly to a suitable discharge point below the level of the filter.

- It is recommended that isolating valves be installed on the pool suction adjacent to the pool wall and on the main drain, skimmer and vacuum connections at the pump suction. A valve should also be fitted on the pool return pipe if the inlets are below water level. The filter is supplied complete with union connections to facilitate equipment removal if ever necessary.
- Inlet, outlet and waste connections should be made to the Multiport Valve. The appropriate connection is indicated on the valve ports.

DECK LEVEL LAYOUT

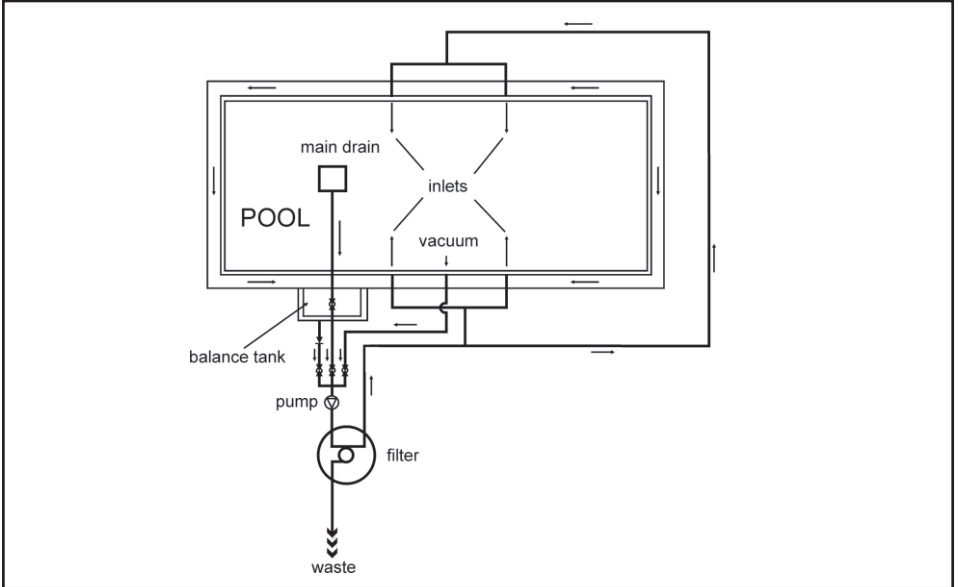

FREE BOARD LAYOUT

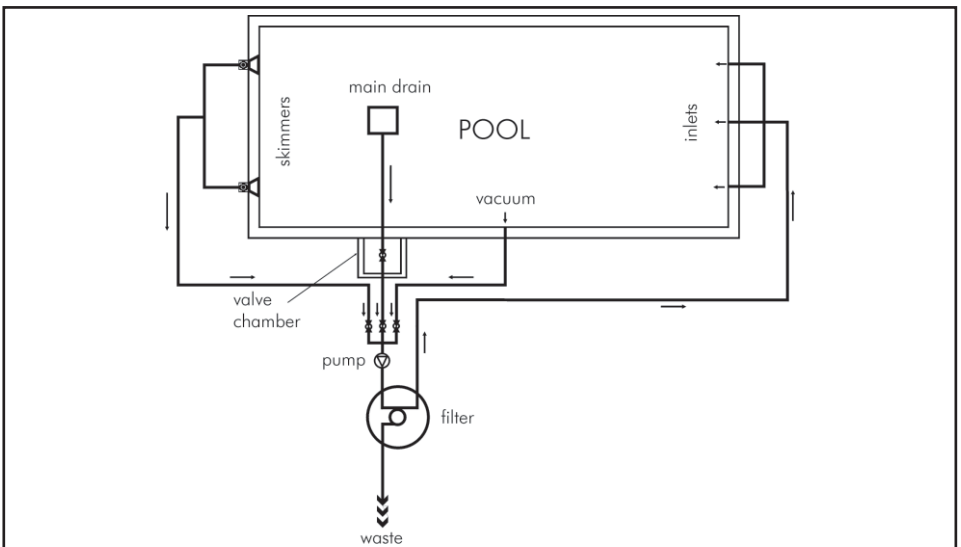

Water Treatment

As determined by site conditions.

2.3 FILTER POSITIONING

When the Multiport Valve is clamped, the handle of the valve in the 'FILTER' position should line up with the manufacturer's name plate. The filter should therefore be positioned to take account of this BEFORE it is charged with media.

2.4 Media Charging Swimming Pools

The filter is provided with suitably graded media which should be poured into the filter as per the details given below. Note the difference for swimming pool and water treatment applications.

MODEL	LAYER 1*			LAYER 2*			LAYER 3*		
	GRADE	DEPTH (MM)	BAGS (No.)	GRADE	DEPTH (MM)	BAGS (No.)	GRADE	DEPTH (MM)	BAGS (No.)
CX 500	C	175	0.6	A	200	1.5	NONE		
CX 600	C	200	1.0	A	250	2.5	NONE		
CX 800	C	250	2.0	A	300	4.0	B	160	2
CX 900	C	330	4.0	A	300	4.0	B	110	2

*Each standard DAYLIFF media bag is 1ft³ (0.03m³) & weighs approx. 50 kgs

Note:

***Sand Grade A - Mesh size (0.5-1.2mm)**

B - Mesh size (2-4mm)

C - Mesh size (5-8mm)

Water Treatment

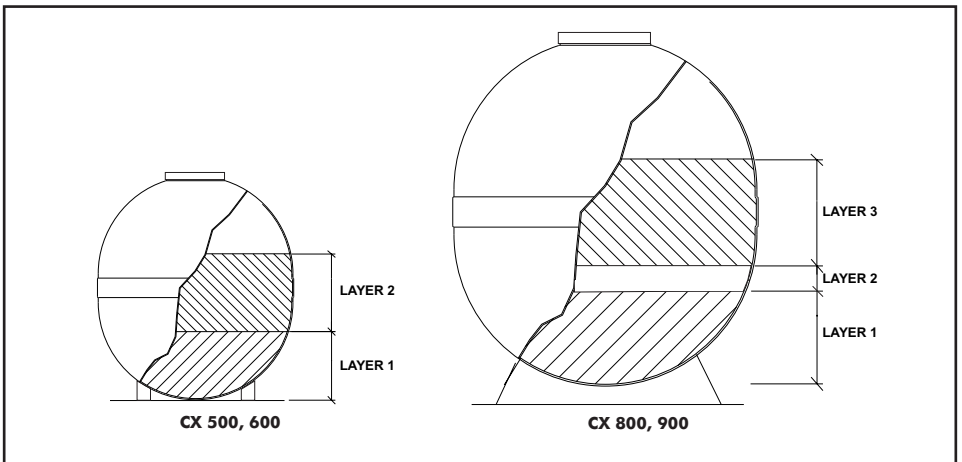

Sand Media - 1st Stage

Filter Model	Filter Area (m ²)	Effective Height (m)	Volume	Best Filtration Flow (m ³ /hr)	Standard Flow (m ³ /hr)	Back wash Flow (m ³ /hr)	Free Board (0.3)	Layer 1*			Layer 2*		Layer 3*	
								Grade	Depth	Bags	Grade	Bags	Grade	Bags
DXD 300	0.08	1.3	0.09	0.8	1.5	2	0.4	C	0.1	0.3	B	2		-
CX 500	0.2	0.5	0.1	2.0	3.9	6	0.4	C	0.1	0.7	B	2		-
CX 600	0.3	0.7	0.2	2.8	5.7	8	0.2	C	0.1	1	B	3		-
CX 800	0.5	0.9	0.5	5	10	15	0.3	C	0.1	1.8	B	8		-
CX 900	0.7	1	0.7	6.7	13	20	0.3	C	0.1	2.4	C	2.	B	11

Sand Media - 2nd Stage

Filter Model	Filter Area (m ²)	Effective Height (m)	Volume	Best Filtration Flow (m ³ /hr)	Standard Flow (m ³ /hr)	Back wash Flow (m ³ /hr)	Free Board (0.3)	Layer 1*			Layer 2*		Layer 3*		Layer 4*	
								Grade	Depth	Bags	Grade	Bags	Grade	Bags	Grade	Bags
DXD 300	0.08	1.3	0.09	0.8	1.5	2.3	0.4	C	0.1	0.3	B	2r	A	1.00		
CX 500	0.20	0.5	0.1	2.0	4	5.9	0.2	C	0.1	0.7	B	2	A	1.00		
CX 600	0.3	0.7	0.2	3	6	8	0.2	C	0.1	1.0	B	3	A	2.00		
CX 800	0.5	1	0.5	5	10	15	0.3	C	0.1	1.8	B	8	A	7.00		
CX 900	0.2	1	0.7	7	13	20	0.3	S	0.1	2.4	C	2	B	2	A	9

Note:

***Sand Grade A - Mesh size (0.5-1.2mm)**

B - Mesh size (2-4mm)

C - Mesh size (5-8mm)

Support (S) - Mesh size (12-18mm)

Activated Carbon

Filter Model	Filter Area (m ²)	Effective Height (m)	Volume	AC Volume	Back wash Flow (m ³ /hr)	Flow Rate (m ³ /hr)		Free Board (0.3)	Support			Activated Carbon		
						EBCT 7.5min	EBCT 5min		Grade	Depth	Bags	Grade	Depth	Bags
DXD 300	0.08	1.3	0.09	0.06	2.3	0.4	1.1	0.4	B	0.1	0.3	AC	0.8	2
CX 600	0.3	2	0.6	0.3	8.5	2.2	6.6	0.6	B	0.1	1	AC	1.0	9
CX 900	0.7	2	1.3	0.7	20.2	5.4	16.1	0.6	B	0.1	3	AC	1.0	22

DMI-65

Filter Model	Filter Area (m ²)	Recommended Bed Depth (m)	Weight of DMI required (kg)	No. of Bags*	Weight of support media Grade 2 (kg)	No. of Bags* Glass Media 2
DXD 300	0.07	0.8	63	3	15	0.6
DXD 500	0.2	1	231	11	38	1.5
CX 600	0.3	1	336	16	75	3
CX 900	0.6	1	840	40	125	5

***Each bag of DMI-65 is 21kg**

Recommended Flow Rate for each filter at a different Iron and Manganese Concentration												
Filter	0.3ppm - 1ppm Iron		>1ppm - 5ppm Iron		>5ppm - 15 ppm Iron		>15ppm Iron		0.5ppm - 1ppm Manganese		>1ppm - 2ppm Manganese	
	Velocity (m/hr)	Max Flow (m ³ /hr)	Velocity (m/hr)	Max Flow (m ³ /hr)	Velocity (m/hr)	Max Flow (m ³ /hr)	Velocity (m/hr)	Max Flow (m ³ /hr)	Velocity (m/hr)	Max Flow (m ³ /hr)	Velocity (m/hr)	Max Flow (m ³ /hr)
DXD 300	20	1.4	15	1	10	0.7	7	0.5	10	0.7	7	0.5
DXD 500	20	4	15	3	10	2	7		10	2	7	
CX 600	20	6	15	4	10	3	7	2	10	3	7	2
CX 900	20	13	15	10	10	6	7	4	10	6	7	4

Glass Media

Media Charging				Recommended Flow Rates for each Filter for various applications		
				RO Water Feed	Standard Filtration	Pools
Filter Model	Filter Area (m ²)	No. of bags for Support Glass Grade 3	No. of bags for Grade 2	Max Flow (m ³ /hr)	Max Flow (m ³ /hr)	Max Flow (m ³ /hr)
CX 500	0.2	1.3	2	3	5	7
CX 600	0.3	2.5	5	4.2	7	10
CX 800	0.50	6	14	7.5	13	18
CX 900	0.6	8	18	10	16	22
DXD 300	0.07	1	1.8	1	2	2
DXD 500	0.2	3	7	3	5	7
CXD 600	0.3	5	12	4	7	10
CXD 900	0.6	12	30	10	16	22

***Each bag of Glass Media is 25Kg**

Anthracite

Filter Model	Filter Area (m ²)	Total Bed Depth	Recommended Charging Bed Depth (m)	Number of Bags			
				Support Glass Media Grade 3	Glass Media Grade 2	Anthracite Media III	Anthracite Media II
CX 500	0.2	0.4	0.3	0	0.75	0	1
CX 600	0.3	0.6	0.4	0	1.5	0.75	1
CX 800	0.5	0.9	0.7	1	2.5	2	3
CX 900	0.6	1	0.7	1	2	4	5
DXD 300	0.07	1	0.8	0	0.5	0	1
DXD 500	0.2	1.3	1	1	1	1	2
CXD600	0.3	2	1	1	2	3	4
CDX 900	0.6	2	1.5	2	3	8	9

	Recommended Flow Rates for each Filter for various applications			
	RO Water Feed		Standard Filtration	
Filter Model	Velocity (m/hr)	Maximum Flow (m ³ /hr)	Velocity (m/hr)	Maximum Flow (m ³ /hr)
CX 500	15	3	25	5
CX 600	15	4	25	7
CX 800	15	7.5	25	13
CX 900	15	10	25	16
DXD 300	15	1	25	2
DXD 500	15	3	25	5
CXD600	15	4	25	7
CDX 900	15	10	25	16

When charging proceed as follows:-

- Unscrew the filter lid bolts and remove the lid.
- Lift off the diffuser from the filter inlet and remove from the filter. The inlet pipe should now be blocked with paper or a cloth to prevent the ingress of media during charging.
- Charge with media as per the instructions given above ensuring that the nylon air breather pipe is not covered by the media.
- Replace the outlet diffuser ensuring that the air bleed is properly secured.
- Replace lid ensuring that no grains of sand are trapped on the filter O-ring seat or on the O-ring itself and then smear the O-ring with petroleum jelly. Then tighten the lid bolts evenly ensuring not to over tighten.

In the event that the top weeps under pressure, undo the bolts and rotate the lid checking first that the lid is properly seated on the filter neck.

2.5 Commissioning

When commissioning, the following procedure must be followed:-

- Open all valves and ensure that the system is primed.
- Set Multiport Valve to 'BACKWASH' and start the pump.
- Check flow at the backwash pipe and allow the pump to run until the backwash water is observed as reasonably clean, a minimum of five minutes being recommended.

This step is essential as the filter media is not fully pre-washed and this procedure rinses the new media clean.

- Note that as the filter is initially empty it will take time to fill and there will be a delay of a minute or two from when the pump is switched on to when flow is observed.
- Stop pump and turn valve to 'RINSE'.
- Start pump and allow media bed to rinse until waste water is observed as clean. Stop pump and turn valve to 'FILTER'.
- Start pump and allow system to operate until a steady flow is noticed at the filter outlet. As the system may not be fully primed it will take time for all air to be expelled.



Under no circumstances should the position of the multiport be changed when the pump is running. Always switch off the pump first or serious equipment damage may result.

3. OPERATION

3.1 Use of Multiport Valve

DAYLIFF filters are fitted with a Multiport Valve to control filter operation. There are six positions on the valve and the various operations possible with the different settings are described below.

FILTER

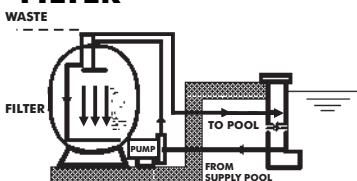

The normal operating position. Water from the pump is fed into the top of the filter and after passing through the media is collected at the bottom. It is then returned to the pool through the inlet pipes.

BACKWASH

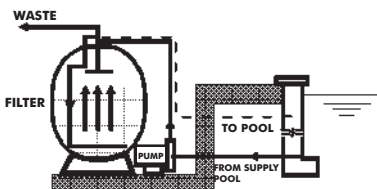

During normal operation the filter will accumulate dirt in the media bed. This is cleaned by a process of backwashing when the filter flow is reversed and water is pumped from the bottom to the top of the filter and then to waste. It should be carried out whenever the filter pressure exceeds the clean running pressure by 0.3Bar, there is a noticeable reduction in inlet flow or weekly, whichever is sooner. The backwashing process normally takes 2-3 minutes and should be continued until the waste water is observed as clean.

RINSE

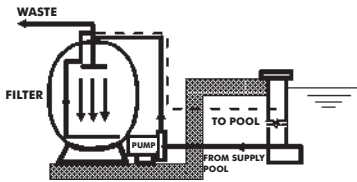

After backwashing the filter media needs to be rinsed. Water is pumped into the top and out of the bottom of the filter as for normal filtering, but it is then discharged to waste. This removes any residual dirt in the media instead of returning it to the supply pool. Rinsing should not take more than one minute and again the sight glass on the side of the valve can be used to see when the water is clear.

RECIRCULATE

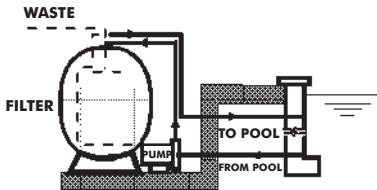

In this position the filter is by-passed and the water is pumped straight to the delivery point. It will normally only be necessary to use this position if there is a problem with the filter itself (e.g. a leak or major blockage). It can also be used to test the filtering pressure drop by comparing normal filtering pressure with recirculation pressure.

WASTE

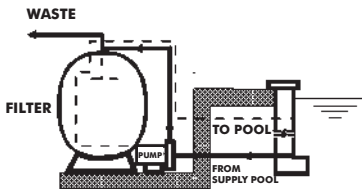

The waste position is used for by-passing the filter to waste. In swimming pool applications make sure that the pump is not switched off once the operation has begun as there may be problems with priming when the water level is below the pump. This position can also be used for vacuuming to waste. This may be necessary if there is a large amount of sediment on the floor of the pool which would rapidly clog the filter in normal operation.

CLOSED

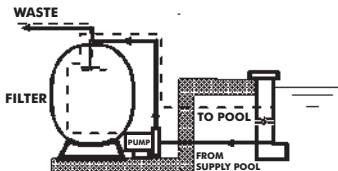

This shuts off all flow to the filter. In pool applications it is most frequently used to isolate the filter when removing the line strainer lid to clean the basket.

3.2 Maintenance of Filters

DAYLIFF filters need no routine maintenance other than regular backwashing. However, over time the media will progressively clog and become less effective. The period will depend upon the pool installation and usage, though is normally some years. Ineffective media becomes apparent through reduced filter efficiency and when this occurs re-charging with new media will be necessary.

Important Note:-

The pipe connections must be correctly done as shown above. Hand tightening is adequate for the MPV unions and under no circumstances should a pipe wrench be used. If the union weeps, add more thread tape on the union threads and make sure to check that the union O-Ring is in place.

4. TROUBLE SHOOTING

FILTER

PROBLEM	POSSIBLE CAUSE	SOLUTION
Water coming out not clear	Flow rate very high	Regulate flow rate to optimal levels to ensure adequate filtration time
	Filter not working well	Check that the filter is in good condition
	Clogged sand filter	Back wash the filter
Low clean water flow	Feed pump not working well	Check that the pump performance has not dropped drastically
	Filter clogged	Back wash the filter
	System's pipeline clogged	Check that the pipeline is not clogged and clean pipe if it's the case
	Feed pump failed	Repair or replace the pump
No water supply at all	Feed pump failed	Repair or replace the pump
	Valve arrangement control	Check the right valves have been closed or opened for the right process operation
	Filter clogged	Backwash the filter

5. TERMS OF WARRANTY

i) General Liability

- In lieu of any warranty, condition or liability implied by law, the liability of Dayliff (hereafter called the Distributor) in respect of any defect or failure of equipment supplied **is limited to making good by replacement or repair** (at the Distributors discretion) defects which under proper use appear therein and arise solely from faulty design, materials or workmanship within a specified period. This period commences **immediately after the equipment has been delivered to the customer** and at its termination all liability ceases. Also the warranty period will be assessed **on the basis of the date that the Distributor is informed of the failure.**
- This warranty applies solely to equipment supplied and **no claim for consequential damages**, however arising, will be entertained. Also the warranty specifically excludes defects caused by fair wear and tear, the effects of careless handling, lack of maintenance, faulty installation, incompetence on the part of the equipment user, Acts of God or any other cause beyond the Distributors reasonable control. Also, any repair or attempt at repair carried out by any other party **invalidates all warranties.**

ii) Standard Warranty

General Terms

If equipment failure occurs in the normal course of service having been competently installed and when operating within its specified duty limits warranty will be provided as follows:-

- **Up to three years - The item will be replaced or repaired at no charge.**
- **Over three years, less than five years - The item will be replaced or repaired at a cost to the customer of 50% of the Davis & Shirliff market price.**

The warranty on equipment supplied or installed by others is conditional upon the defective unit **being promptly returned free to a Davis & Shirliff office** and collected thereafter when repaired. No element of site repair is included in the warranty and any site attendance costs will be payable in full at standard chargeout rates. Also proof of purchase including the purchase invoice must be provided for warranty claim to be considered.

DAYLIFF is a brand of **Davis & Shirtliff**

for enquiries contact

Davis & Shirtliff, Ltd.

P.O. Box 41762 - 00100, Nairobi, Kenya

Tel: 6968000/ 0711 079 000

or visit

www.dayliff.com

for details of the nearest branch or stockist